

AIRRAID®

INTAKE SYSTEMS

#200-104 INSTALLATION INSTRUCTIONS 1988-1995 Chevy V8 305 & 350 TBI

Thank you for purchasing the Airaid Intake System. Please read the instruction manual carefully before proceeding with the installation. Contact Airaid @ (800) 498-6951 8:00 AM - 5:00 PM MST weekdays for questions regarding fit or instructions that are not clear to you. Your Airaid Intake System was carefully inspected and packaged. Check that no parts are missing, or were damaged during shipping. If any parts are missing, contact Airaid. The air filter element is protected from direct exposure to water and debris; care should be taken not to drive through deep water. WATER INGESTION IS THE DRIVERS RESPONSIBILITY! The air filter is reusable and should be cleaned using the Airaid Filter Tune-Up Kit periodically.

Thank you for selecting Airaid.



Packing List:

700-420	Airaid Premium Filter	1
KIT104H	Plastic "Hat"	1
KIT104TAC	13" x 3.5" Tube	1
KITP300	3.5" x 3.5" Coupler	1
KIT104HP	Hardware Pack	1
- KIT104G	5.25" Gasket	1
- KITSNP16M4	Black Speed Clamp	2
- KIT104STUD	Bent Black Stud	1
- KIT104NUT	Aluminum Polished Nut	1
- KIT104B	Silver Bracket	1

Packing List (cont'd):

- KITELBOW1	90° Plastic Elbow	1
- KITHOSE01	½" x 4" Hose	1
- KITGRMT03	Rubber Grommet	1
- KIT31CNNEH	Serrated 5/16-18 Nut	1
- KIT60CNFHPZ	M6-1 Hex Nut	1
- KIT31C75HCS5	5/16-18 x ¾ Hex Bolt	1

Tools Required for this Installation:

Flat Head Screwdriver
Ratchet Wrench w/6' Extension
5/16, 3/8, 10mm & 13mm Socket or Wrench

Installation Instructions. Read Me!

I DISCONNECT NEGATIVE (-) BATTERY CABLE

II Remove Factory Intake Assembly

- a) Loosen the wing on the top of the factory air intake assembly and remove assembly from vehicle.
- b) Remove and discard the 1" crankcase breather ring. **See Fig#1** (save valve cover breather tube for later use)
- c) Use a 13mm socket and wrench to remove the strap that secures the silencer tube on the passenger side fender housing. **See Fig#2**
- d) Remove entire factory air cleaner assembly from vehicle.

III 1987-1992 : Install the AIRAID Throttle Body Stud and Airaid Hat

- a) Replace the "S" shaped threaded stud into the top of the throttle body. (Note: also screw the 6mm serrated nut onto the stud.) **See Fig#3**

IV 1993-1995: Install the AIRAID Throttle Body Stud and Airaid Hat

- a) Remove the two air cleaner hold down studs with a 5/16" wrench. **See Fig# 4**. Take care not to loosen throttle body.
- b) Screw the "S" shaped 1/4"x20 threaded stud into the top of the throttle body. (Note: The factory threaded hole is 1/4"x20 thread, located in front of the injectors and between the throttle bores.) **See Fig#3**
- c) Also screw the 6mm serrated nut onto the stud. **See Fig#3**

V Mount the AIRAID Intake System Brace

- a) Locate the dipstick tube mounting bracket on the passenger side cylinder head. Using a 3/8" socket, remove the bolt and save for later use.
- b) Carefully pull the dipstick away from the cylinder head and position the silver Airaid mounting bracket between the cylinder head and the dipstick bracket. **See Fig#5**
- c) Reinstall bolt and tighten loosely so that adjustments may be made later.

VI Assemble and Install the AIRAID Intake System (Refer to Fig#6 & Fig#7)

- a) Check for and remove any foreign debris in the intake tube and filter.
- b) Insert rubber grommet into the hole in the rear of the Airaid hat.
- c) Insert the black plastic elbow into the grommet hole in the rear of the Airaid hat.
- d) Place the supplied gasket around the top perimeter of the throttle body.
- e) Position the Airaid hat over the throttle body and guide over the Airaid stud.
- f) Tighten the Airaid hat loosely with the billet nut provided.
- g) Insert 1/2"x 4" hose over plastic elbow and connect to valve cover breather tube, secure using the two black clamps provided.
- h) Slide the stainless steel clamp with rubber insert over the opening of the Airaid hat.
- i) Insert the silver Airaid tube into the stainless steel coupler, connecting the tube to the hat.
- j) Align the tab on the tube with the end of the bracket attached to the dipstick bracket and fasten with the hardware provided.

VI Finishing Up

- a) Tighten all clamps, brackets, nuts & bolts.
- b) Inspect overall work and check hood clearance.
- c) Re-connect negative battery cable.

References

FIG#1



FIG#2



FIG#3

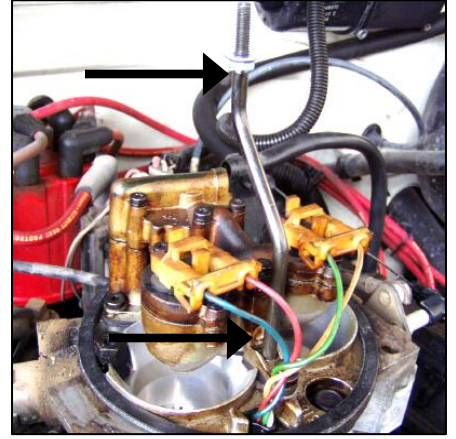

FIG#4

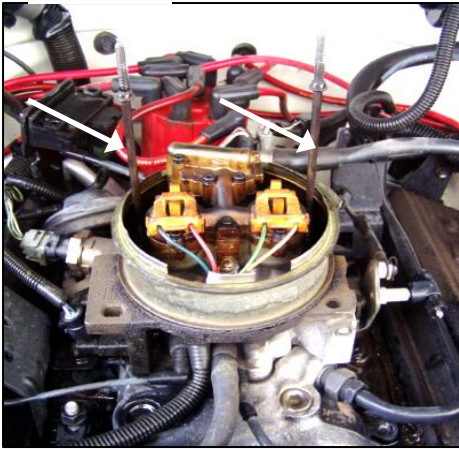

FIG#5

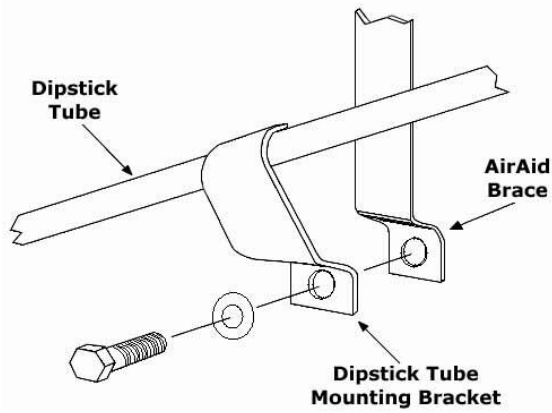

FIG#6

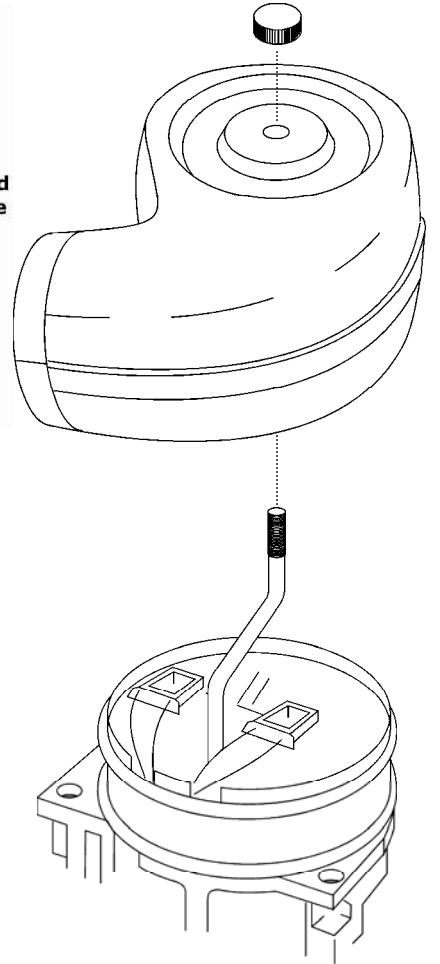

FIG#7

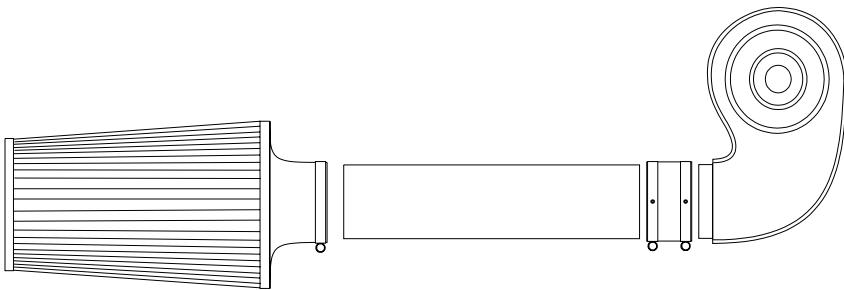

Don't Forget Your AIRAID Filter Tune-Up Kit!

P/N 790-551



Before



After!



VEHICLE WARRANTY INFORMATION

Airaid Intakes and Filters will NOT void your vehicle's warranty. The federal Magnuson-Moss Warranty Act of 1975 states that the manufacturer can't void a vehicle's warranty because an aftermarket part is used. This is called a tie-in sale. Which means a manufacturer can't require the use of a certain brand of product. The only exception to this is the condition they provide the product for free. For assistance or more information the Federal Trade Commission can be contacted at 1-877-FTC-HELP (1-877-382.4357).

Rev. 02/01/07