

AIR RAID®

INTAKE SYSTEMS

#200-167 INSTALLATION INSTRUCTIONS

2005 Chevy HD Truck

Duramax Diesel (Does not fit 2005 GMC)

Thank you for purchasing the Airaid Intake System. Please read the instruction manual carefully before proceeding with the installation. Contact Airaid @ (800) 498-6951 8:00 AM - 5:00 PM MST weekdays for questions regarding fit or instructions that are not clear to you. Your Airaid Intake System was carefully inspected and packaged. Check that no parts are missing, or were damaged during shipping. If any parts are missing, contact Airaid. The air filter element is protected from direct exposure to water and debris; care should be taken not to drive through deep water. WATER INGESTION IS THE DRIVERS RESPONSIBILITY! The air filter is reusable and should be cleaned using the Airaid Filter Tune-Up Kit periodically.

Thank you for selecting Airaid.



Packing List:

700-469	Airaid Premium Filter	1
KIT1121MAFADA	Black Filter Adapter	1
KIT167MAFC	Front Cool Air Dam Panel	1
KIT167RRDAMC	Rear Cool Air Dam Panel	1
KITHUMPHS05	Urethane Hump Hose	1
KITCOUPLER01	Urethane Coupler	1
KIT154T	Modular Intake Tube	1
KITWSTRIP02	Weather Strip 21"	1
KIT167HP	Hardware & Instructions	1
- KIT10BHCP50	8-32 x 1/2" Button Screw	2
- KIT6NWSAPZ	#6 Flat Washer	5
- KIT6CNKEPZ	6-32 Nut	5

Packing List (cont'd):

- KIT6C31MXPPZ	6-32 x 5/16" Screw	5
- KIT15DHC3050	1/4-20 Button Head Bolt	3
- KIT09FWZ019	1/4" Flat Washer	7
- KIT60C250HCS	M6-1x25 Hex Bolt	4
- KIT10ANSSWAS	#10 AN Flat Washer	2
- KITBIT#T20	#T20 Security bit	1
- KITHS60	#60 Hose Clamp	2
- KITHS72	#72 Hose Clamp	2

Tools Required for this Installation:

Flat Head Screwdriver
 8mm, 10mm socket
 3/32" Allen Wrench
 5/32" Allen Wrench

Installation Instructions. Read Me!



1. Disconnect negative battery cable. Using supplied T-20 security bit, remove factory mass air sensor (save for later use).



2. Remove factory filter minder and grommet.



3. Loosen hose clamps on factory intake tube assembly and remove from engine. Unsnap factory air box assembly and remove from vehicle.



4. Using a 10mm socket, remove the five bolts and plate from engine compartment.

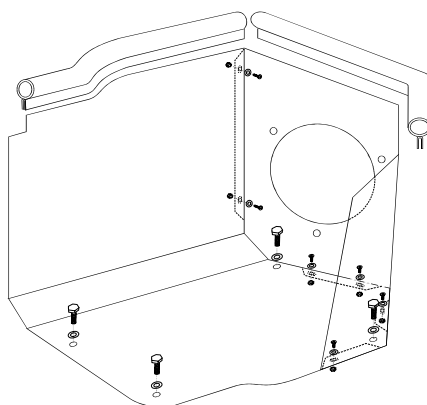

5. Assemble Airaid Cool Air Dam panels using the supplied #6 screws, washers and nuts.

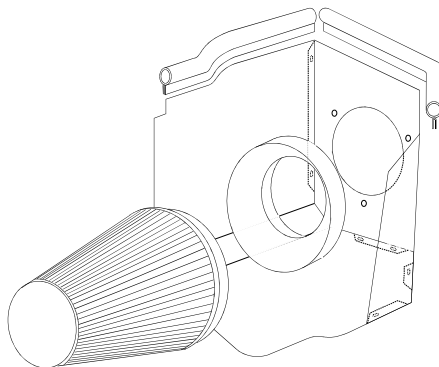

6. Using the three supplied 1/4 - 20 button head bolts and washers, install the air filter adapter on the Airaid Cool Air Dam.



7. Install Airaid Cool Air Dam assembly in engine compartment using the four supplied bolts, and washers.



8. Using the supplied 8-32 allen head bolts and washers, install factory mass air sensor into Airaid intake tube. (*Note: Sensor must be installed in direction shown in picture.*)



9. Install factory rubber grommet and air filter minder in Airaid intake tube.



- 10.** Install supplied hump hose and two #72 hose clamps onto large end of Airaid intake tube. (*Note: Leave hose clamps loose until final assembly.*)



- 11.** Install coupler and two #60 hose clamps onto small end of Airaid intake tube. (*Note: Leave hose clamps loose until final assembly.*)



- 12.** Install Airaid tube assembly onto engine. Position coupler and hump hose and tighten hose clamps. Connect wire harness to mass air sensor. (*Note: There should be a gap between the Airaid intake tube and the air filter adapter.*)



- 13.** Install the supplied Airaid filter on the air filter adapter. Install the supplied weather strip on the Airaid Cool Air Dam. (*Note: Start from one corner and work your way around to insure proper alignment of weather strip.*)

- 14.** Double check your work to be certain that all nuts, bolts, and clamps are securely fastened.

- 15.** Reconnect the negative battery cable.



Included with your Airaid Intake System is a sticker with a California Air Resources Board (C.A.R.B.) Executive Order (EO) number. This sticker must be placed in plain view inside of the engine compartment. Failure to do so may prevent you from passing a smog inspection.

Before



After!



Don't Forget Your AIRAID Filter Tune-Up Kit!



P/N 790-550

Instructions Revision
Date: 11/07/07