

AIR AID®

INTAKE SYSTEMS

The C.A.R.B. E. O. Number For This Kit, Only Includes 2006 Thru 2008 Models. All Others Pending.

Installation Instructions
Part Number 200-195
2006-10 Chevrolet HHR
2.2L & 2.4L I-4 Non Turbocharged
Automatic Transmission Only

Packing List:

#1	720-440	Airaid Premium Filter	1
#2	KIT195BPC	Bottom Panel	1
#3	KIT1951PSPC	Passenger Side Panel	1
#4	KIT1951DSPC	Driver Side Panel	1
#5	KIT195T	Airaid Intake Tube	1
#6	KITWSTRIP02	Weather Strip 47 1/2"	1
	KIT195HP	Hardware & Instructions	1
#7	KIT15DHC3050	1/4"-20x1/2" Button Head Bolt	3
#8	KIT09FWZ019	1/4" Flat Washer	3
#9	KIT1420WZZF	1/4" Serrated Nut	1
#10	KIT15BHC3038	8-32x3/8" Button Head Screw	2
#11	KIT6C31MXPPZ	6-32x 5/16" Screw	13
#12	KIT6NWSAPZ	#6 Flat Washer	13
#13	KIT6CNKEPZ	6-32 Keps Nut	13
#14	KIT195B	Bracket	1
#15	KITBMP01	Silicone Bumpers	3
#16	KITGRMT12	Large Grommet	1
	KITBIT01	#20 Torx Bit	1

Tools Required For Installation:

1/4", 5/16" Sockets
 Ratchet & Extension
 Phillips Screwdriver
 3/32", 5/32" Allen Wrenches
 7/16" Wrench
 #20 Torx Bit (Supplied)

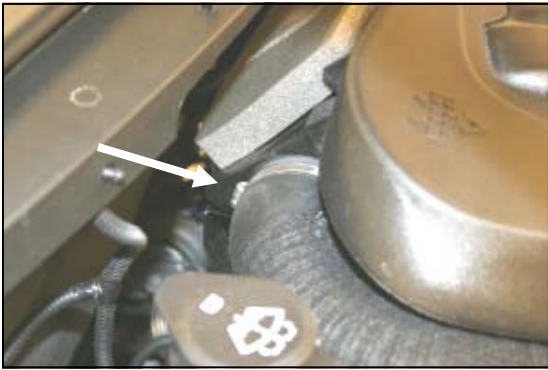
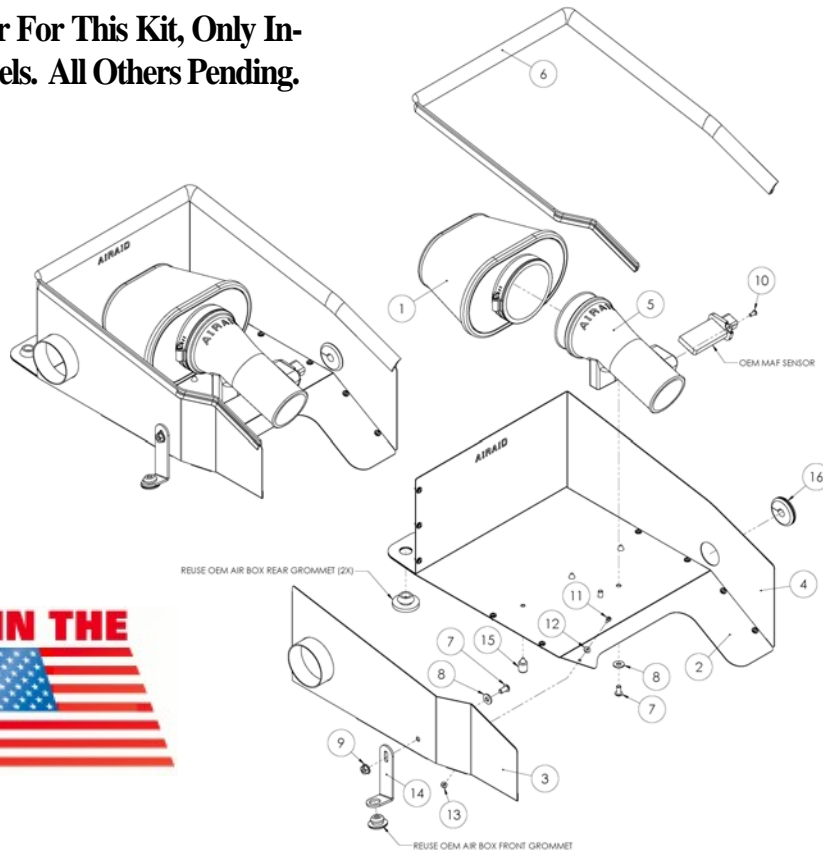

1. **Disconnect the negative battery cable.** With a 1/4" socket, loosen the hose clamp that holds the fresh air intake tube to the factory air cleaner housing. Slip the tube off of the factory air cleaner housing and set it aside, it will be re-connected later in the install.



2. Loosen the hose clamp that holds the rubber elbow to the factory air cleaner housing. Next squeeze the tab on the Mass Air Flow sensor wiring connector, and remove the connector from the Mass Air Flow sensor.

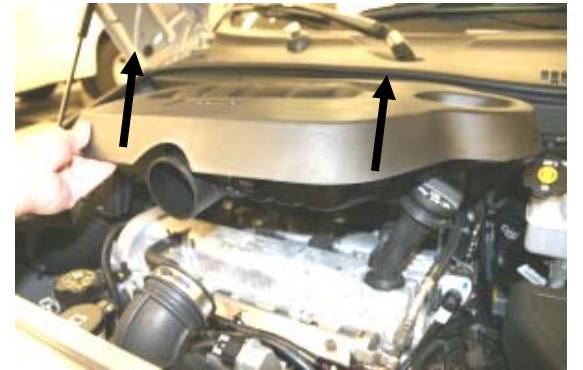

3. Remove the factory air filter housing by lifting on the front, and then the rear. There are no bolts holding it down, only 3 rubber grommets.



4. Using the supplied #20 torx bit, remove two screws, and the Mass Air Flow sensor from the factory air cleaner housing. Set it aside for re-installation later in the install.



5. Remove 3 factory rubber grommets from the factory air cleaner housing.



6. Assemble the three Cool Air Dam panels (#2, #3, & #4), using 13 screws (#11), washers (#12), and nuts (#13), as shown.

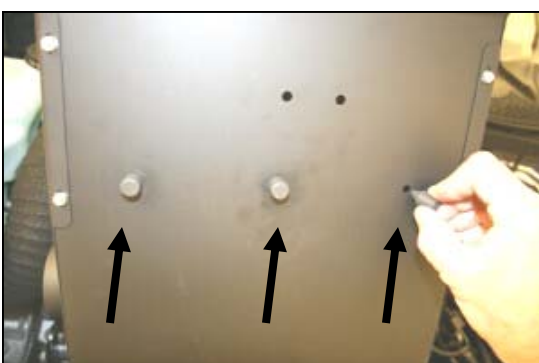

7. Install the three silicone bumpers (#15) into the three holes in the bottom of the Cool Air Dam, as shown.

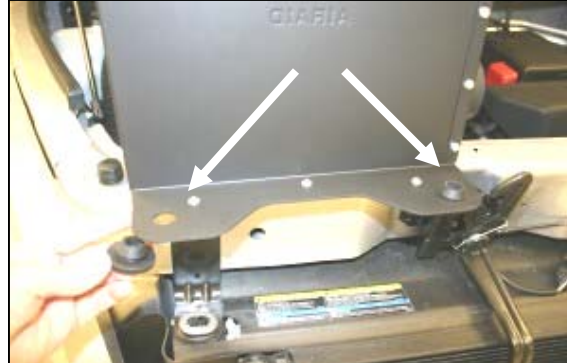

8. Install the two large factory grommets removed from the factory air cleaner housing in step #5, into the two holes at the back of the Airaid Cool Air Dam.



9. Install the Mass Air Flow sensor removed in step #4, into the Airaid Intake Tube (#5) using the two 8/32"x 3/8" button head screws (#10). **DO NOT USE THE FACTORY SCREWS!**



10. Install the Airaid Intake Tube onto the CAD using two 1/4-20 x 1/2" button head bolts (#7) and 1/4" flat washers (#8), threaded up from the bottom of the CAD.



11. Install the assembled CAD into the vehicle by lowering the front into the vehicle first, and then aligning the two grommets on the studs at the rear of the engine. Push down firmly on the rear of the CAD to seat the grommets. Next slide the factory rubber elbow onto the Airaid Intake Tube.

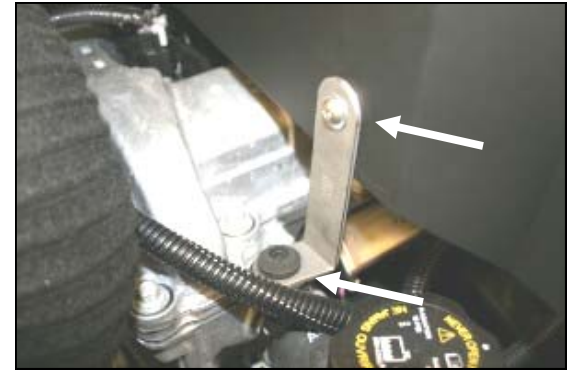

12. Install the small factory grommet removed in step #5 into the supplied bracket (#14). Next slip the installed grommet over the stud on the front of the engine, and bolt the bracket to the CAD using one 1/4-20x 1/2" button head bolt (#7), 1/4" flat washer (#8), and 1/4" serrated nut (#9).



13. Slide the Mass Air Flow sensor connector thru the hole in the side of the CAD, and install the "split" grommet (#16) over the wiring loom as shown.

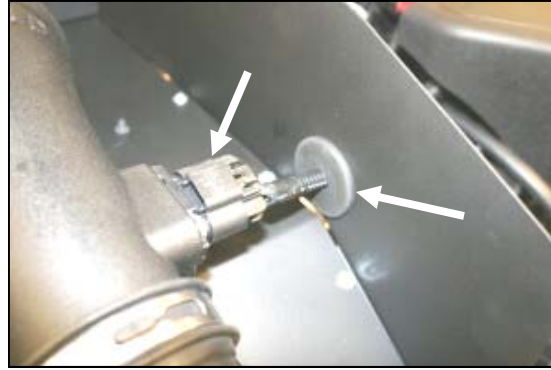

14. Re-connect the wiring connector to the MAF, and then seat the large grommet into the hole in the side of the CAD.

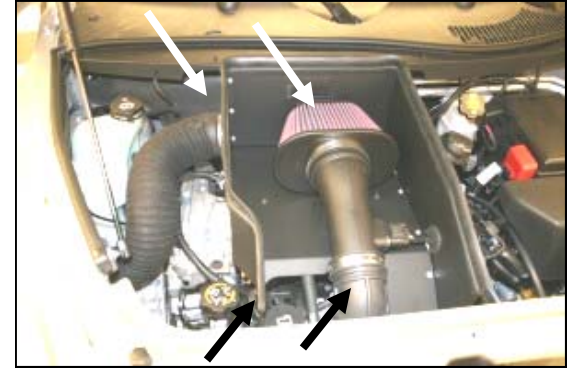

15. Install the Airaid Premium Filter (#1) onto the Airaid Intake Tube, and tighten the clamp. Install the weather strip (#6) on top of the CAD starting at the front corner, and working your way to the other corner. Reconnect the factory fresh air tube to the CAD, and tighten the hose clamp. Adjust the factory rubber elbow on the Airaid Intake Tube, and tighten the hose clamp.

16. Double check your work!

Make sure there is no foreign material in the intake path. Make sure all clamps, hoses, bolts, and screws are tight.

17. Reconnect the negative battery cable!

Included with your Airaid Intake System is a sticker with a California Air Resources Board (C.A.R.B.) Executive Order (EO) number. This sticker must be placed in plain view inside of the engine compartment. Failure to do so may prevent you from passing a smog inspection.

Before!



After!



Thank you for purchasing the Airaid Intake System. Contact Airaid @ (800) 498-6951 8:00 AM - 5:00 PM MST weekdays for questions regarding fit or instructions that are not clear to you. Your Airaid Intake System was carefully inspected and packaged. Check that no parts are missing, or were damaged during shipping. If any parts are missing, contact Airaid. The air filter element is protected from direct exposure to water and debris; care should be taken not to drive through deep water. WATER INGESTION IS THE DRIVERS RESPONSIBILITY! The air filter is reusable and should be cleaned using the Airaid Filter Tune-Up Kit periodically.

Don't Forget Your AIRAID Filter Tune-Up Kit!



P/N 790-551 Aerosol Spray
P/N 790-550 Squeeze Spray



Instructions Revision
Date: 02/11/10