

AIR AID®

INTAKE SYSTEMS

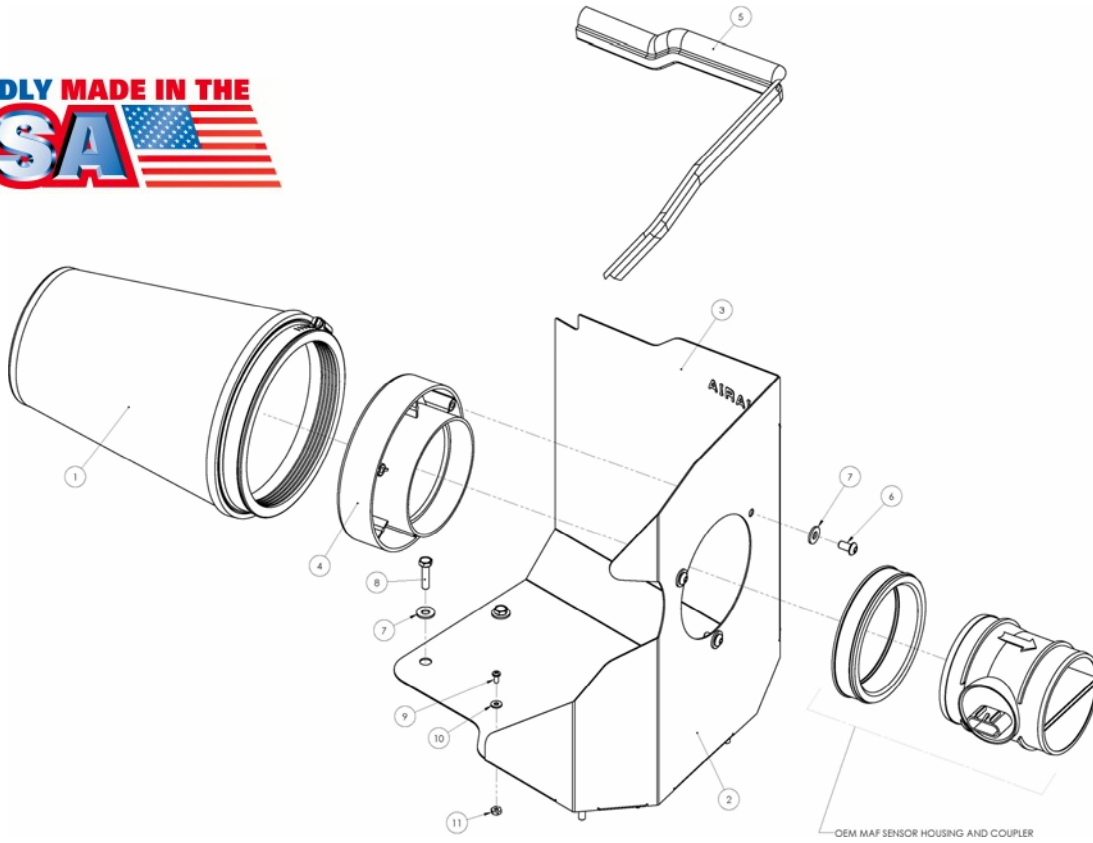

Installation Instructions
Part Number 200-196
2007-2008 Chevrolet Silverado
1500/2500/3500
Tahoe/Suburban/Avalanche/
GMC Sierra 1500/2500/3500
Yukon/Yukon XL/
Denali/Denali XL
Cadillac Escalade/ESV/EXT
4.3L, 4.8L, 5.3L, 6.0L, 6.2L
(GMT-900 Body Style Only)

Packing List:

| | | | |
|-----|---------------|-----------------------------|---|
| #1 | 700-469 | Airaid Premium Filter | 1 |
| #2 | KIT196MAFDC | MAF Panel Coated | 1 |
| #3 | KIT196RRDAMC | Rear Air Dam Coated | 1 |
| #4 | KIT1121MAFADA | Black Filter Adapter | 1 |
| #5 | KITWSTRIP02 | Weather Strip 20 3/4" | 1 |
| | KIT196HP | Hardware & Instructions | 1 |
| #6 | KIT15DHC3050 | 1/4"-20x1/2" SS Button Head | 3 |
| #7 | KIT09FWZ019 | 1/4" Flat Washer | 7 |
| #8 | KIT60C250HCS | M6 x 1.25 Hex Bolt | 4 |
| #9 | KIT6C31MXPPZ | 6-32 x 5/16" Screw | 5 |
| #10 | KIT6NWSAPZ | #6 Flat Washer | 5 |
| #11 | KIT6CNKEPZ | 6-32 Keps Nut | 5 |

Tools Required For Installation:

5/16", 10mm Socket
 Ratchet & Extension
 Phillips Screwdriver
 5/32" Allen Wrench



1. **Disconnect the negative battery cable.** Loosen the hose clamp on the end of the factory intake tube at the Mass Air Flow sensor, next loosen the hose clamp that holds the Mass Air Flow sensor to the factory air box.



2. Remove the Mass Air Flow sensor from between the factory intake tube and the factory air box. Use caution to retain the rubber coupler on the Mass Air Flow sensor.



3. Without disconnecting the wiring harness, set the Mass Air Flow sensor out of the work area. Next rock the factory air box back and forth, lift it up, and remove it from the hold down grommets. There are no bolts holding it down.



4. Remove the factory air box from the vehicle.

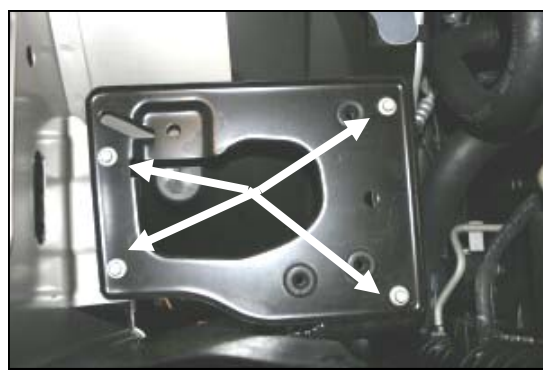

5. Remove 4 bolts, and remove the factory air box mounting plate.



6. Assemble the two Cool Air Dam panels (#2) and (#3) using the five supplied screws (#9), washers (#10), and nuts (#11), as shown.

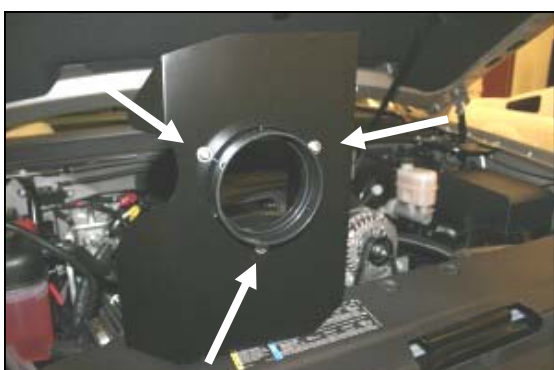

7. Install the filter adapter (#4) into the CAD using three button head bolts (#6), and washers (#7).

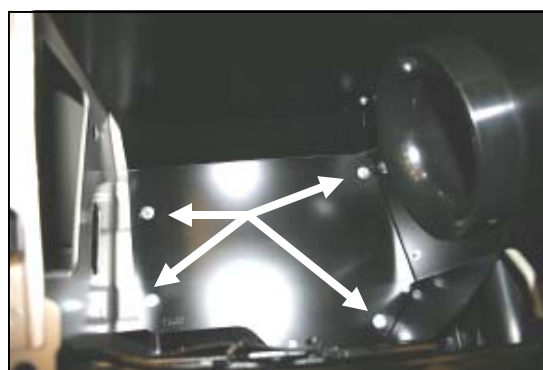

8. Install the assembled CAD in place of the factory air box using four bolts (#8) and washers (#7). Do not over tighten the bolts.

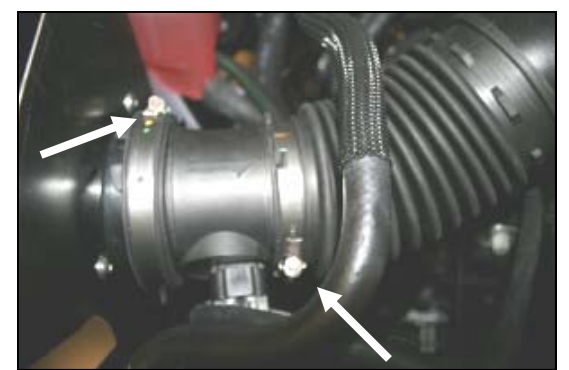

9. Re-install the Mass Air Flow sensor and coupler onto the air filter adapter (#4), as shown and tighten the hose clamp. Next re-connect the factory intake tube to the Mass Air Flow sensor, and tighten the hose clamp.



10. Install the Airaid Premium Filter (#1) onto the filter adapter (#4), and tighten the hose clamp. Next install the weather strip (#5) onto the top of the CAD as shown. For ease of installation start at the fender, and work towards the radiator.

11. Double check your work!

Make sure there is no foreign material in the intake path. Make sure all clamps, hoses, bolts, and screws are tight.

12. Reconnect the negative battery cable!

Thank you for purchasing the Airaid Intake System. Contact Airaid @ (800) 498-6951 8:00 AM - 5:00 PM MST weekdays for questions regarding fit or instructions that are not clear to you. Your Airaid Intake System was carefully inspected and packaged. Check that no parts are missing, or were damaged during shipping. If any parts are missing, contact Airaid. The air filter element is protected from direct exposure to water and debris; care should be taken not to drive through deep water. **WATER INGESTION IS THE DRIVERS RESPONSIBILITY!** The air filter is reusable and should be cleaned using the Airaid Filter Tune-Up Kit periodically.

Included with your Airaid Intake System is a sticker with a California Air Resources Board (C.A.R.B.) Executive Order (EO) number. This sticker must be placed in plain view inside of the engine compartment. Failure to do so may prevent you from passing a smog inspection.

Before!

After!



Don't Forget Your AIRAID Filter Tune-Up Kit!



**P/N 790-551 Aerosol Spray
P/N 790-550 Squeeze Spray**

Instructions Revision
Date: 11/08/07