

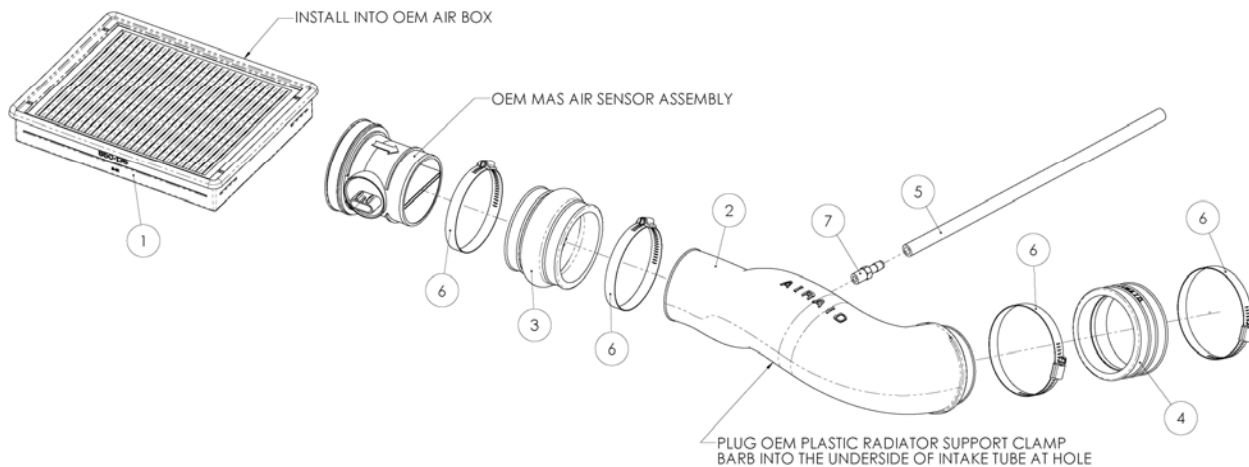

## Installation Instructions

Part Number: 200-996 MIT OR  
 Part Number: 200-796 Jr. Kit  
 2007-08 Chevrolet Silverado 1500  
 Tahoe/Suburban/Avalanche/  
 GMC Sierra 1500  
 Yukon/Yukon XL  
 Denali/Denali XL  
 Cadillac Escalade/ESV/EXT  
 4.8L, 5.3L, 6.0L, 6.2L V-8  
 \*GMT-900 Body Style Only\*  
 \*Electric Cooling Fans Only\*



## Packing List:

#1	*850-135	Airaid Premium Filter	1
#2	KIT996T	Modular Intake Tube	1
#3	KITHUMPS18	Urethane Hump Hose	1
#4	KITCOUPLER10	Urethane Coupler	1
#5	KITHOSE06	3/8" x 14" Breather Hose	1
	KIT996HP	Hardware & Instructions	1
#6	KITHS64	#64 Hose Clamp	4
#7	KITFITTING01	1/4"NPT x 3/8" Barb Fit.	1

\* Filter included only in 200-796 kit

## Tools Required For Installation:

5/16" Socket  
 Ratchet & Extension  
 Flat Screwdriver  
 #25 Torx Bit (200-796 Kit Only)



1. **Disconnect the negative battery cable.**  
 Remove the factory beauty cover by lifting up on the front, and then pulling the cover towards the front of the vehicle. It is only held in place by grommets.



2. Disconnect the factory breather hose at the valve cover.



3. Separate the factory intake tube from the plastic clamp bar that secures the radiator hose to the tube. A firm downward push will usually do it.

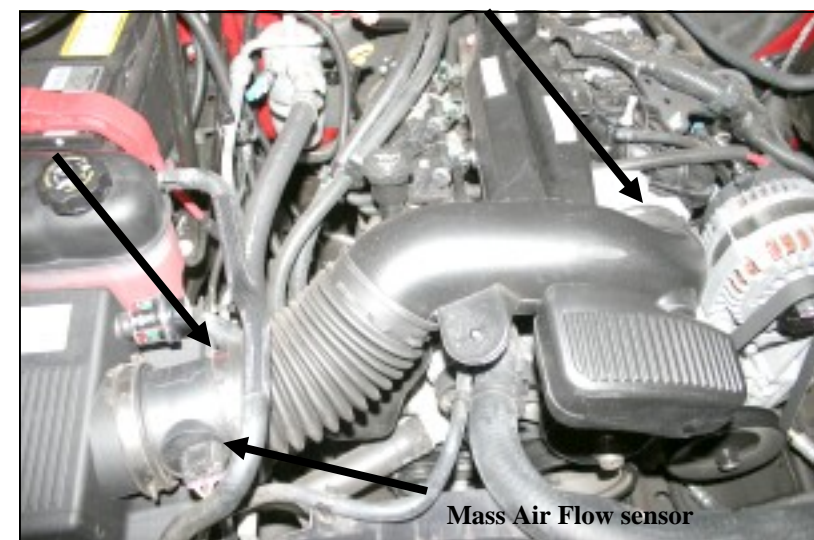

4. Loosen two hose clamps on the factory intake tube. One at the throttle body end, and the other at the Mass Air Flow sensor (MAF) end.



**5.** Slide the factory intake tube off of the MAF sensor, rotate it up so that it disengages from the mounting grommet on the intake manifold, and then slide it forward off of the throttle body and remove it from the vehicle.



**6.** Install the urethane coupler (#4) on the throttle body end of the Modular Intake Tube (#2) with two #64 hose clamps (#6). Install the urethane hump hose (#3) on the other end of the MIT with the remaining two #64 hose clamps. Leave all clamps loose for now. Install the 3/8" barbed fitting (#7) into the MIT, and slide the 3/8" breather hose (#5) over the barbed fitting as shown.



**7.** If you purchased the 200-996 kit, proceed to step #9. If you purchased the 200-796 Jr. Kit, remove 4 screws in the factory airbox with a #25 Torx bit, and remove the factory air filter. Proceed to step #8.



**8.** Install the Airaid Premium filter (#1) into the factory airbox, and re-install the 4 screws.



**9.** Install the MIT onto the MAF first, and then onto the throttle body. Adjust for fit, and tighten the hose clamps. Next connect the breather hose to the factory breather port on the valve cover. Reinstall the factory hose clamp barb back into the hole in the bottom of the MIT. Reinstall the beauty cover.

**10. Double check your work!**

Make sure there is no foreign material in the intake path. Make sure all clamps, hoses, bolts, and screws are tight.

**11. Re-connect the negative battery cable!**

Thank you for purchasing the Airaid Intake System. Contact Airaid @ (800) 498-6951 8:00 AM - 5:00 PM MST weekdays for questions regarding fit or instructions that are not clear to you. Your Airaid Intake System was carefully inspected and packaged. Check that no parts are missing, or were damaged during shipping. If any parts are missing, contact Airaid. The air filter element is protected from direct exposure to water and debris; care should be taken not to drive through deep water. WATER INGESTION IS THE DRIVERS RESPONSIBILITY! The air filter is reusable and should be cleaned using the Airaid Filter Tune-Up Kit periodically.

**Don't Forget Your AIRAID Filter Tune-Up Kit!**



P/N 790-551 Aerosol Spray  
P/N 790-550 Squeeze Spray

**Before!**



**After!**



Instructions Revision  
Date: 08/28/07