

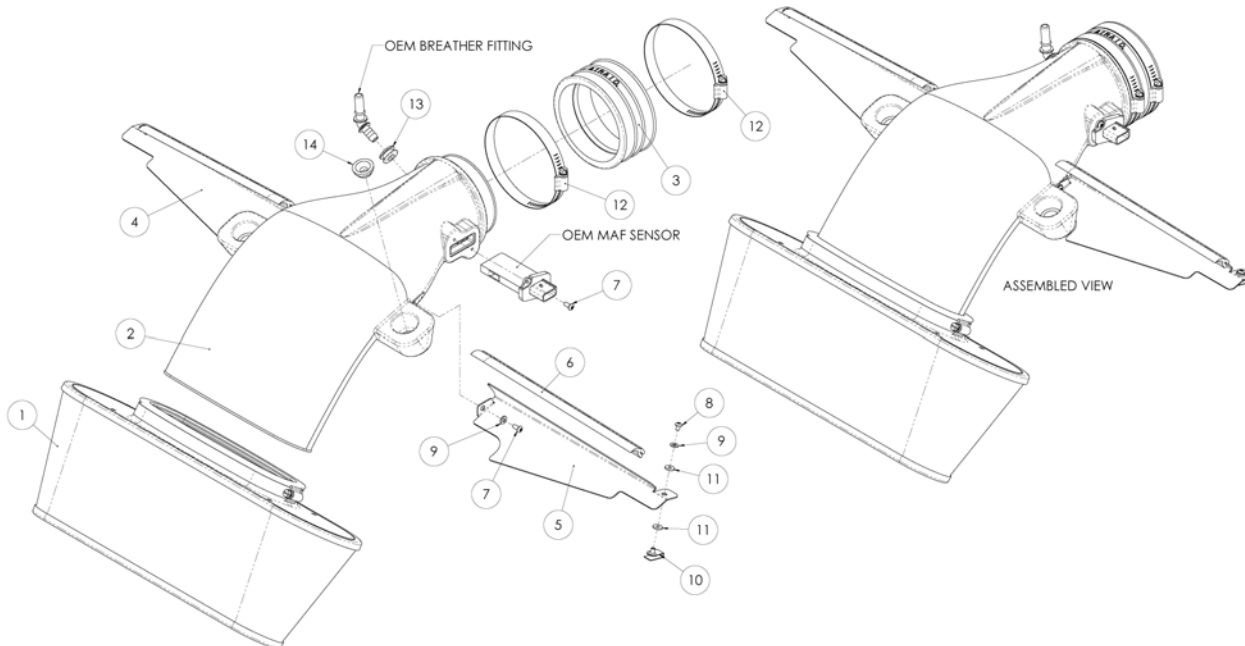

INTAKE SYSTEMS



Installation Instructions Part Number 250-230 2008-09 Chevrolet C-6 Corvette LS3 6.2L V-8

Packing List:

#1	720-475	Airaid Premium Filter	1
#2	KIT216T	Airaid Intake Tube	1
#3	KITCOUPLER10	Urethane Coupler	1
#4	KIT230PSPC	Passenger Side Air Dam	1
#5	KIT230DSPC	Driver Side Air Dam	1
#6	KITWSTRIP02	Weather Strip 9 1/2"	2
	KIT230HP	Hardware & Instructions	1
#7	KIT15BHC3038	8-32 x 3/8" Button Head Screw	4
#8	KIT15BHC3016	8-32 x 1/4" Button Head Screw	2
#9	KIT15FW3016	#8 Flat Washer	4
#10	KITNUT02	8-32 Clip Nut	2
#11	KITWASH01	Small Rubber Washer	4
#12	KITHS64	#64 Hose Clamp	2
#13	KITGRMT13	Grommet	1
#14	KITGRMT15	Grommet	2

Tools Required For Installation:

5/16" Socket
Ratchet & Extension
3/32" Allen Wrench
#20 Torx Bit



1. Disconnect negative battery cable.
Remove the grey security clip on the bottom of the Mass Air Flow sensor wiring connector. Next squeeze the tab on the bottom of the connector, and disconnect the wiring harness from the sensor. Now loosen the hose clamp holding the tube to the throttle body.



2. Squeeze the tabs on the sides of the crankcase breather connector, and disconnect the breather hose from the factory intake tube breather fitting.



3. Lift up on the factory intake tube assembly to disengage the grommets from the three grommet posts and throttle body. Remove the assembly from the vehicle.



4. Using a #20 Torx Bit, remove the two factory screws that hold the MAF sensor into the factory intake tube. Remove the MAF sensor for reinstallation in step #7.



5. Remove the factory breather fitting from the factory intake tube and save it for reinstallation in step #6.



6. Install the provided grommet (#13) into the hole in the Airaid Intake Tube (#2). Next install the factory plastic breather fitting removed in step #5 into the grommet.



7. Reinstall the Mass Air Flow sensor removed in step #4, into the Airaid Intake Tube using two 8-32x3/8" button head bolts (#7).
Do Not Use The Factory Screws!
Next, install the urethane coupler (#3) onto the Airaid Intake Tube using two #64 hose clamps (#12) as shown. Tighten only the clamp closest to the MAF sensor.



8. Attach the two air dams (#5 driver side & #4 passenger side) onto the Airaid Intake Tube using one 8-32x1/4" button head bolt (#8) and #8 flat washer (#9) on each side. Leave the bolts slightly loose for now to allow for adjustment.



9. Using a flat blade screwdriver, pry up the center pin in the grommet post closest to the right fender on the radiator shroud, and remove both pieces of the grommet post from the vehicle.



10. Set the Airaid Premium Filter into the area in front of the radiator. It will be mounted in step # 15.



11. Install the provided grommets (#15), narrow side down, into the Airaid Intake Tube as shown. Make sure that they are seated all the way into the bottom of the holes.



12. Install the Airaid Intake Tube assembly onto the throttle body first, and then align the grommets over the factory grommet posts on top of the radiator shroud. Push down on the grommets to seat them on the posts. (*Hint: Use a 1/2" deep socket to help seat the grommets onto the posts.*) Now tighten the hose clamp on the throttle body.



13. Slide one clip nut (#10) over the outside end of the plastic radiator cover and align it with the hole in the air dam. Install one rubber washer (#11) over the threads of the clip nut, and then align the air dam hole over the washer. Add one more rubber washer, one #8 flat washer (#9), and one 8-32x1/4" button head bolt (#8) to secure the air dam. Repeat this step on the passenger side. Refer to the line drawing on page one.



14. Tighten all four button head bolts that secure the air dams to the intake tube, and the radiator shroud.



15. Slide the Airaid Premium Filter up onto the end of the intake tube and tighten the clamp. Reconnect the **MAF** sensor wiring harness and replace the grey security clip. Reconnect the factory breather hose to the breather fitting. Install the weather strip (#6) onto the top of the air dams as shown.

16. Double check your work!

Make sure there is no foreign material in the intake path. Make sure all clamps, hoses, bolts, and screws are tight.

17. Reconnect the negative battery cable!

Before!



After!



Thank you for purchasing the Airaid Intake System. Contact Airaid @ (800) 498-6951 8:00 AM - 5:00 PM MST weekdays for questions regarding fit or instructions that are not clear to you. Your Airaid Intake System was carefully inspected and packaged. Check that no parts are missing, or were damaged during shipping. If any parts are missing, contact Airaid. The air filter element is protected from direct exposure to water and debris; care should be taken not to drive through deep water. WATER INGESTION IS THE DRIVERS RESPONSIBILITY! The air filter is reusable and should be cleaned using the Airaid Filter Tune-Up Kit periodically.

Don't Forget Your AIRAID Filter Tune-Up Kit!



P/N 790-551 Aerosol Spray
P/N 790-550 Squeeze Spray



Instructions Revision
Date: 07/30/08