

# AIRRAID®

## INTAKE SYSTEMS

### #300-155 INSTALLATION INSTRUCTIONS 2004-07 DODGE RAM 5.9L CUMMINS DIESEL

*(Note: Use P/N 300-128 for vehicles w/out optional “quiet hood pad”)*

Thank you for purchasing the Airaid Intake System. Please read the instruction manual carefully before proceeding with the installation. Contact Airaid @ (800 ) 498-6951 8: 00 AM - 5 :00 PM MS T weekdays for questions regarding fit or instructions that are not clear to you. Your Airaid Intake System was carefully inspected and packaged. Check that no parts are missing, or were damaged during shipping. If any parts are missing, contact Airaid. The air filter element is protected from direct exposure to water and debris; care should be taken not to drive through deep water. WATE R INGESTION IS THE DRIVERS RESPONSIBILITY! The air filter is reusable and should be cleaned using the Airaid Filter Tune-Up Kit periodically.

*Thank you for selecting Airaid.*



#### Packing List:

720-128 Airaid	Premium Filter	1
KIT155RPC	Rear Air Dam Panel	1
KIT155FPC	Front Air Dam Panel	1
KIT8A Filt	er Adapter Tube	1
KITWSTRIP02	Weather Strip 24 1/4"	1
KIT155HP	Hardware & Instructions	1
-KIT15FW3016	#8 Flat Washer	2
-KIT25C62HCSS	1/4-20 x 5/8" Hex Bolt	3

#### Packing List (cont'd):

-KIT09FWZ019	1/4" Flat Washer	3
-KIT6C31MXPPZ	6-32 Phillips Screw	4
-KIT6CNKEPZ	6-32 Nut	4
-KIT6NWSAPZ	#6 Washer	4
-KIT15BHCP3063	8-32 Button Head Screw	2

#### Tools Required for this Installation:

Flat Head Screwdriver  
7mm & 8mm Sockets & Ratchet  
3/32" Allen Wrench, T-20 bit

# Installation Instructions. Read Me!

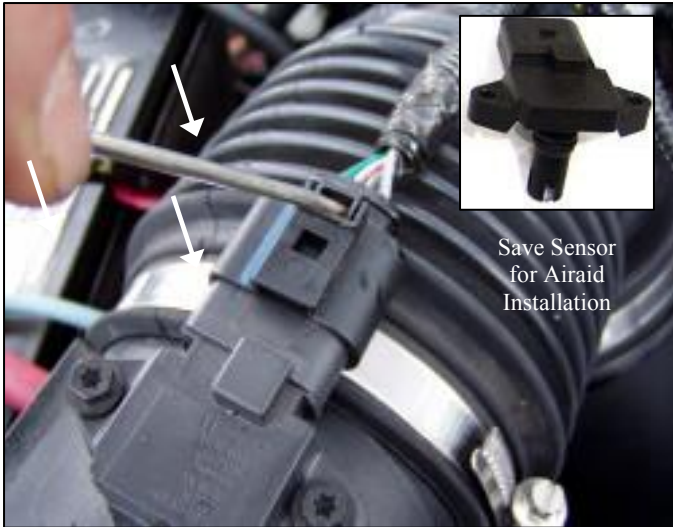

1. Disconnect the negative battery cable and disconnect the electrical connector. Using the T-20 bit loosen the two star head bolts and remove the electrical sensor. (Retain sensor for installation of Airaid Intake System)



2. Unclip the factory air box lid and remove the lid assembly from vehicle.

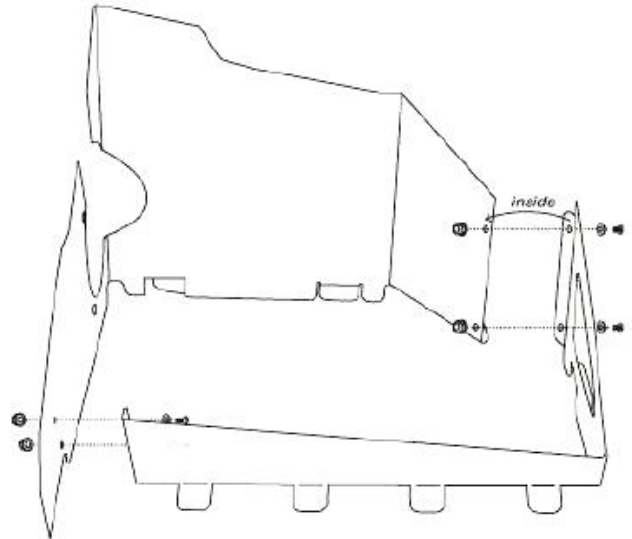

3. Assemble Airaid Quick Fit Cool Air Dam panels using the (4) 6/32 screws, washers and nuts provided.

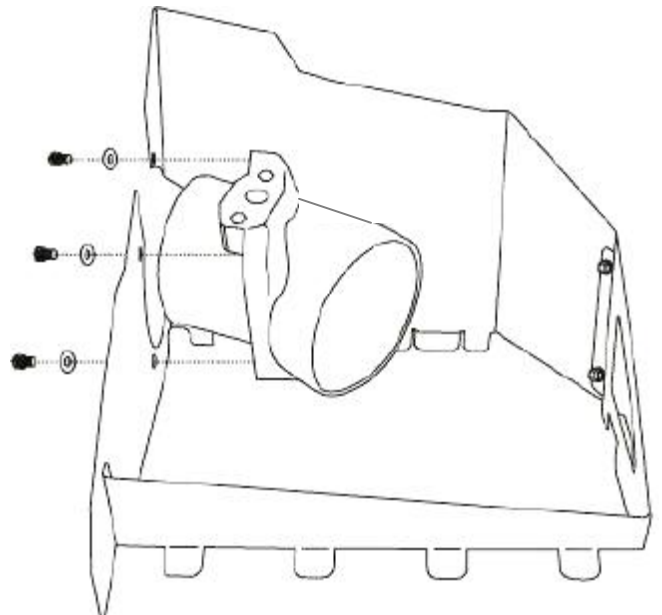

4. Assemble the air filter adapter to the cool air dam using the (3) 1/4-20 bolts and washers provided.

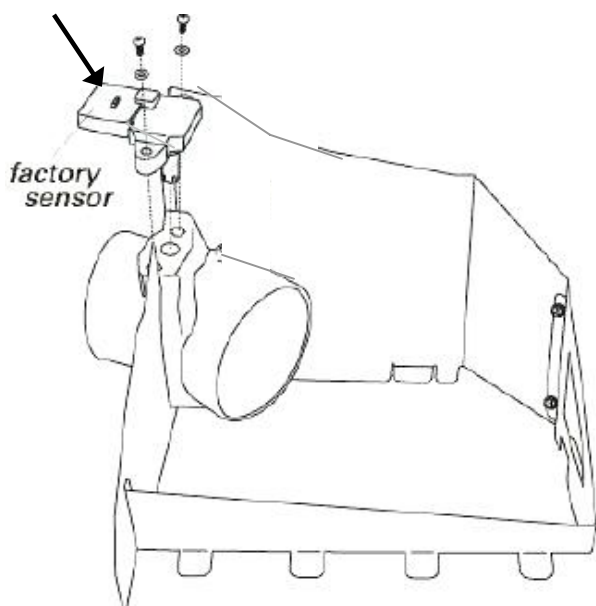

5. Fasten the factory sensor on top of the adapter using the (2) 8/32 screws and washers using a 3/32 Allen Wrench.



6. Install Airaid intake assembly in place of the factory air box lid & tighten factory hose clamp on intake tube to Airaid system & secure air intake tube to adapter using the factory hose clamp.

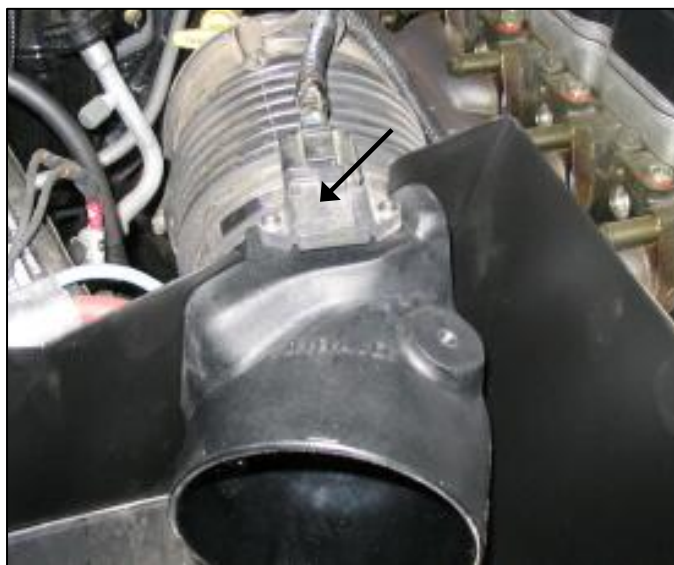

7. Re-connect the wire harness to the sensor on top of the Airaid adapter.

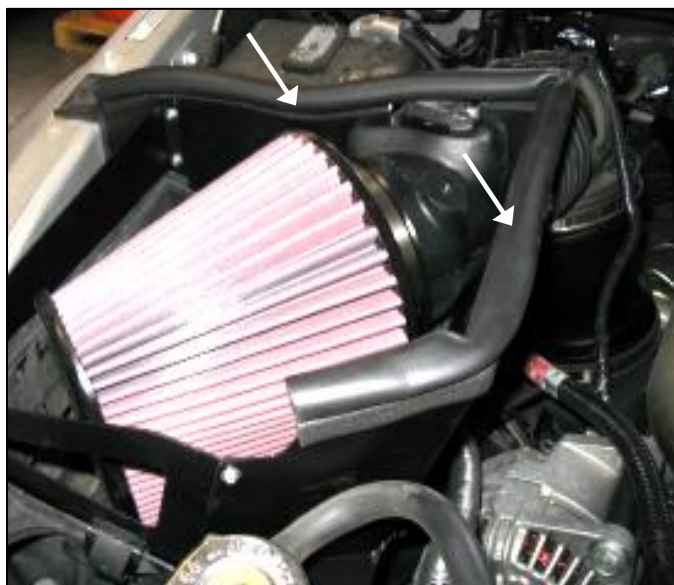

8. Mount Airaid Premium Filter to the filter adapter and tighten hose clamp, in addition; press the weather strip onto the top of the Airaid cool air dam. (*Hint: start the install at the top corner of the cold air dam & work toward the edges*)
9. Double check your work to be certain that all nuts, bolts, and clamps are securely fastened.
10. Reconnect the negative battery cable.

*Before*



*After!*



Included with your Airaid Intake System is a sticker with a California Air Resources Board (C.A.R.B.) Executive Order (EO) number. This sticker must be placed in plain view inside of the engine compartment. Failure to do so may prevent you from passing a smog inspection.

## Don't Forget Your AIRAID Filter Tune-Up Kit!

P/N 790-550



**Airaid Modular Intake Tube P/N 300-928 is also available for this application to replace the factory silencer tube. Please contact your local dealer for details.**

Instructions Revision  
Date: 07/26/10