

AIR RAID®

INTAKE SYSTEMS

400-114 INSTALLATION INSTRUCTIONS 1999 - June 04 FORD 5.4L SUPER DUTY V8/V10

Thank you for purchasing the Airaid Intake System. Please read the instruction manual carefully before proceeding with the installation. Contact Airaid @ (800) 498-6951: 8:00 AM - 5:00 PM MST Weekdays for questions regarding fit or instructions that are not clear to you. Your Airaid Intake System was carefully inspected and packaged. Check that no parts are missing or damaged during shipping. If any parts are missing, contact Airaid. The air filter element is protected from direct exposure to water and debris in its new location. Care should be taken not to drive through deep water. **WATER INGESTION IS THE DRIVERS RESPONSIBILITY!** The air filter is reusable and should be cleaned using the Airaid Filter Tune-Up Kit periodically.

Thank you for selecting Airaid.



Included with your Airaid Intake System is a sticker with a **California Air Resources Board (C.A.R.B.) Executive Order (EO) number**. This sticker must be placed in plain view inside of the engine compartment. Failure to do so may prevent you from passing a smog inspection.

Parts List:

700-445	Filter	x1
KIT114RBPC	Rear Back Panel	x1
KIT114LSPC	Left Side Panel	x1
KIT114FAC	Filter Adapter	x1
KIT114HP	Hardware Pack	x1
KIT114WS	Weather Strip	x1

Hardware Pack:

INSTRUCTION SHEET		x1
KIT114B	Bushing	x3
KIT114G	Gasket 4.5"	x1
KIT25C87HCSS	¼"x20x7/8" Bolts	x3
KIT25CNNES	¼"x20 Nuts	x3
KIT09FWZ019	¼" Washers	x6
KIT6C31MXPPZ	32x5/16" Screw	x6
KIT6CNKEPS	6/32 Nuts	x6
KIT6NWASAPZ	#6 Washer	x6

Tool List:

7/16" Wrench or Socket
10mm Wrench or Socket
Standard Screwdriver
Phillips Screwdriver



Installation Instructions. Read Me!

I DISCONNECT NEGATIVE (-) BATTERY CABLE.

II Remove air filter.

- Loosen clamp and separate. Remove filter.
- Remove the **FRONT** half of air box, simply “pull up” to release. No tools needed. **See Fig#2**
- These parts are not reinstalled in Airaid kit.
- CAUTION: Do Not remove the REAR half of the air box or the “V”-BAND CLAMP.**

III Remove air cleaner bracket.

- Unbolt the 4 retaining bolts (10mm), and remove the bracket (**See Fig#2**) from the engine compartment.
- Save the 4 bolts to reuse later. The bracket is not reused.

IV Assemble Airaid Cool Air Dam.

- Bolt the two panels together with the supplied #6 hardware. **See Fig#1**
- Bolt the Filter Adapter to the Back Panel with the supplied 1/4” hardware.

V Install in vehicle.

- Set in place of the removed bracket.
- Use the 4 saved 10mm bolts to fasten the Airaid assembly into the existing bracket mounting holes.

VI Connect to Airaid.

- Slip supplied Rubber Gasket onto the 4.5” stub on the end of the Airaid assembly. This gasket will make a seal between the Airaid and the stock rear half once connected. **Be sure gasket is in place.**
- Slide stock rear half toward the Airaid and secure with the factory “V”-BAND CLAMP.
- Press weather seal on to top edge of air box.

VII Finishing up

- Check that no foreign objects are in the intake path.**
- Check throttle linkage for full open and closed travel.
- Reconnect battery terminal. Enjoy!

Figure #1

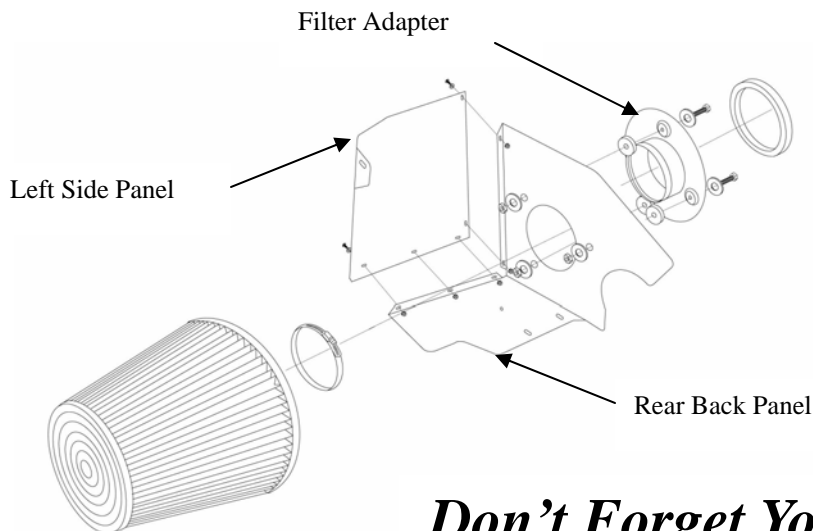
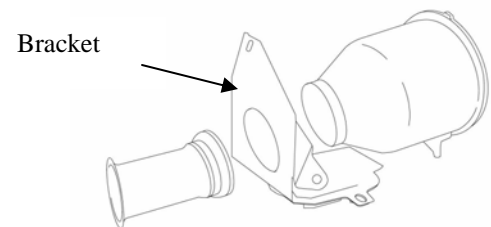

Figure #2



**Don't Forget Your
Airaid Filter Tune-
Up Kit!**



***P/N 790-550**

Rev. 06/14/07